

**easyquip**  
IT CAN BE DONE

[www.easyquip.com.au](http://www.easyquip.com.au)



PRODUCT CATALOGUE  
**WASTE HANDLING  
EQUIPMENT**

**AUSTRALIA'S TRUSTED WASTE EQUIPMENT SUPPLIER**

# ABOUT EASYQUIP

Since 1993, Easyquip have been designing, developing and manufacturing a wide range of waste bins and related products.

As a company we are passionate about developing new, innovative ways of managing waste for our customers, and pride ourselves on our ability to provide solutions. Easyquip maintains the highest of quality standards, making us a trusted waste and recycling management partner.

Easyquip is an Australian family owned company, with locally designed and manufactured products. It can be done with Easyquip!



## SUPPLYING AUSTRALIA FROM:

### VICTORIA

135 Firmins Lane  
Hazelwood North VIC 3840

### QUEENSLAND

299 Stapylton Road  
Heathwood QLD 4110

Talk to us about your next waste handling equipment requirement.



**1300 797 543**

Scan code/visit [easyquip.com.au](http://easyquip.com.au)



# TABLE OF CONTENTS



Frontlift Bins  
Page 04



Hooklift Trays  
Page 17



Roll Over  
Tippler Bins  
Page 26



Twin Lids for  
Frontlift Bins  
Page 07



Hooklift Skel  
Frames  
Page 18



Draw Back  
Tippler Bins  
Page 27



Prop-A-Lid for  
Frontlift Bins  
Page 08



Rolling Lids for  
Hooklift Bins  
Page 19



Transportable  
Blade Compactors  
Page 28

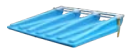

Easylid for  
Frontlift Bins  
Page 09



Hydraulic Lids for  
Hooklift Bins  
Page 20



Stationary Twin  
Auger Compactors  
Page 29



Loading Dock  
Frontlift Bin  
Page 10



Tarps for  
Hooklift Bins  
Page 21



Transportable  
Auger Compactors  
Page 30



Hooklift Bins  
Page 11



Plastic Lids for  
Hooklift Bins  
Page 22



Stationary Blade  
Compactors  
Page 31



Crane Certified  
Hooklift Bins  
Page 13



Load Spreading Auger  
for Hooklift Bin  
Page 23



Stationary Auger  
Compactors  
Page 32



Hooklift Sludge Bins  
Page 15



Forklift Bin  
Page 24

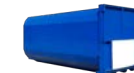

Compactor  
Receiver Bins  
Page 33



Hooklift Mini Bins  
Page 16



Scrap Bin  
Page 25

# FRONTLIFT BINS

We have been manufacturing Front lift bins for the Waste Industry since 1994. Our standard bin design features fully seal welded internal joins, 3mm body sheets, 5mm castor pads and lift pockets.

All Easyquip Frontlift bins are available with a solid steel front panel or the optional mesh front panel for recyclables and can be fitted with Easyquip Twin lids, the Spring assisted Prop-A-Lid or the Counterbalanced Easylid.



## FEATURES

- Meets Industry Standards.
- Full internal welding.
- Durable proven design.
- No sharp edges.
- Consistent quality and attention to detail.

## SPECIFICATIONS

- Floor, walls and ends 3mm Steel.
- Lift pockets 5mm steel.
- Wheel channels 5mm Mild steel.
- All internal seams fully welded.
- Side reinforcing 50x50x5 angle.
- Floor reinforcing 50x50x5 angle.
- Front reinforcing 50x50x3 RHS.
- Lock lug.
- Handles to allow easy movement on castors.
- Truck Hooks to allow movement of bin with truck.
- Drain Socket and plug (Solid front bins).
- 2 x 20mm drain holes in floor (Mesh front bins).
- Mesh front panel 50mm x 50mm opening with 4mm wire. (Mesh front bins).
- Primed and painted in Industrial Enamel.



## OPTIONS

- Forklift pockets under floor.
- Sealed floor (No drain socket).
- Castors.
- Hot Dip Galvanizing.
- Autolock gravity bin lock.



# FRONTLIFT BINS

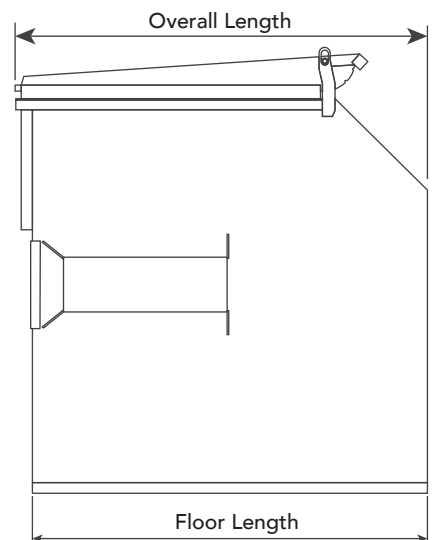
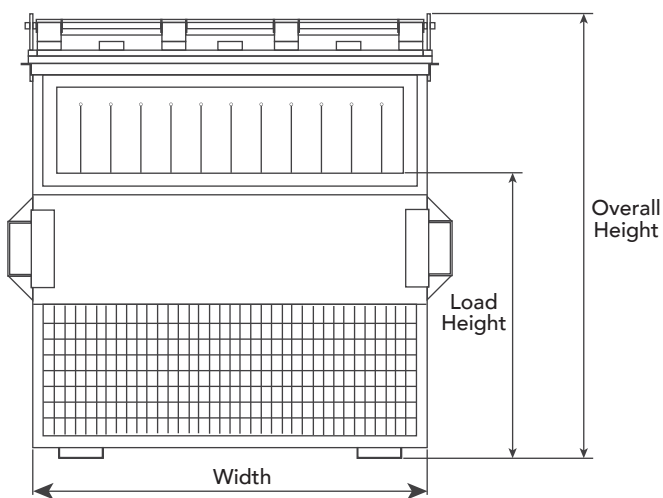
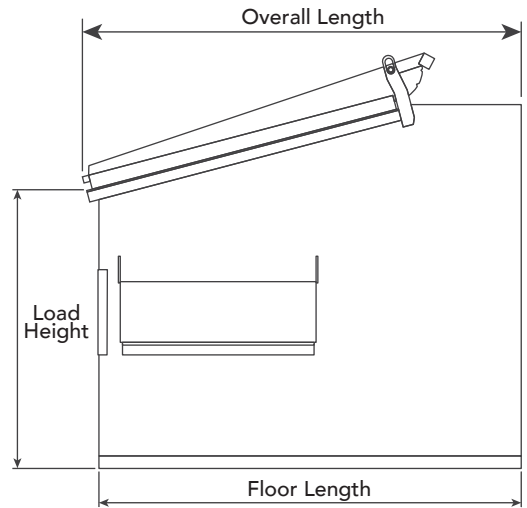
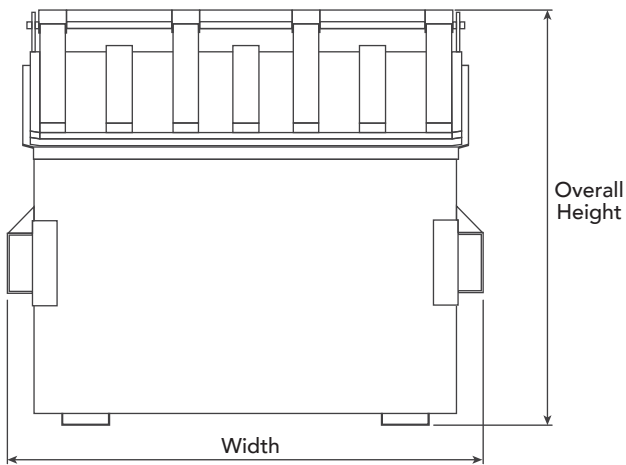
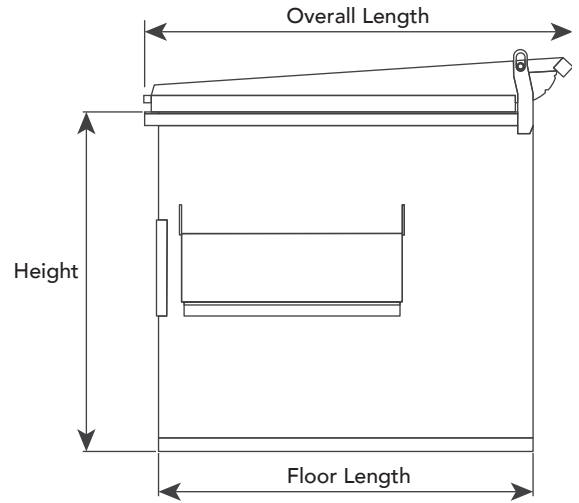
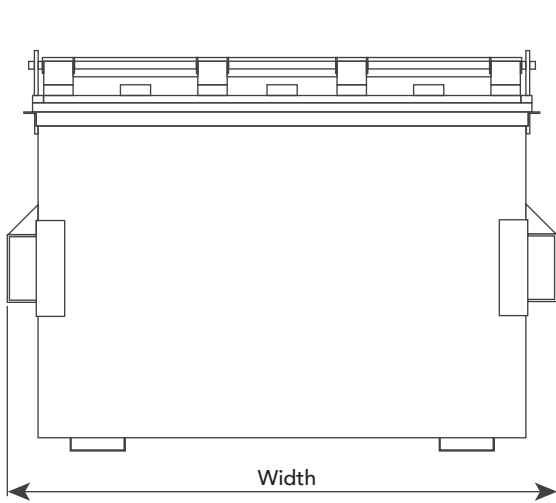

# FRONTLIFT BINS

Item Code	Description	Weight (kg)	Width (mm)	Floor Length (mm)	Overall Length (mm)	Load Height (mm)	Overall Height (mm)
FL15BEL	1.5m <sup>3</sup> Frontlift bin, Box with Easylid	265	2020	900	1120	970	1190
FL15BTL	1.5m <sup>3</sup> Frontlift bin, Box with Twin lids	235	2020	900	1050	970	1090
FL15TTL	1.5m <sup>3</sup> Frontlift bin, Tapered with Twin lids	235	2020	850	1050	970	1090
FL30BEL	3.0m <sup>3</sup> Frontlift bin, Box with Easylid	410	2020	1380	1660	1270	1570
FL30BTL	3.0m <sup>3</sup> Frontlift bin, Box with Twin lids	365	2020	1380	1510	1270	1390
FL30TEL	3.0m <sup>3</sup> Frontlift bin, Tapered with Easylid	410	2020	1330	1660	1270	1570
FL30TTL	3.0m <sup>3</sup> Frontlift bin, Tapered with Twin lids	365	2020	1330	1510	1270	1390
FL30SEL	3.0m <sup>3</sup> Frontlift bin, Slope with Easylid	410	2020	1430	1510	970	1825
FL30STL	3.0m <sup>3</sup> Frontlift bin, Slope with Twin lids	365	2020	1430	1510	970	1700
FL45BEL	4.5m <sup>3</sup> Frontlift bin, Box with Easylid	505	2020	1800	1880	1470	1750
FL45BTL	4.5m <sup>3</sup> Frontlift bin, Box with Twin lids	460	2020	1800	1880	1470	1590
FL45SEL	4.5m <sup>3</sup> Frontlift bin, Slope with Easylid	505	2020	1800	1910	1270	1900
FL45STL	4.5m <sup>3</sup> Frontlift bin, Slope with Twin lids	460	2020	1800	1910	1270	1780
FL45REL	4.5m <sup>3</sup> Frontlift bin, Rubber Slot with Easylid	485	2020	1800	1660	1500	2150
FL45RTL	4.5m <sup>3</sup> Frontlift bin, Rubber Slot with Twin lids	440	2020	1800	1510	1500	1980
FL60REL	6.0m <sup>3</sup> Frontlift bin, Rubber Slot with Easylid	555	2020	1800	1870	1500	2150
FL60RTL	6.0m <sup>3</sup> Frontlift bin, Rubber Slot with Twin lids	500	2020	1800	1870	1500	1980
FLM15BEL	1.5m <sup>3</sup> Frontlift bin, Mesh front, Box with Easylid	265	2020	900	1120	970	1190
FLM15BTL	1.5m <sup>3</sup> Frontlift bin, Mesh front, Box with Twin lids	235	2020	900	1050	970	1090
FLM15TTL	1.5m <sup>3</sup> Frontlift bin, Mesh front, Tapered with Twin lids	235	2020	850	1050	970	1090
FLM30BEL	3.0m <sup>3</sup> Frontlift bin, Mesh front, Box with Easylid	385	2020	1380	1660	1270	1570
FLM30BTL	3.0m <sup>3</sup> Frontlift bin, Mesh front, Box with Twin lids	340	2020	1380	1510	1270	1390
FLM30TEL	3.0m <sup>3</sup> Frontlift bin, Mesh front, Tapered with Easylid	385	2020	1330	1660	1270	1570
FLM30TTL	3.0m <sup>3</sup> Frontlift bin, Mesh front, Tapered with Twin lids	340	2020	1330	1510	1270	1390
FLM30SEL	3.0m <sup>3</sup> Frontlift bin, Mesh front, Slope with Easylid	385	2020	1430	1510	970	1825
FLM30STL	3.0m <sup>3</sup> Frontlift bin, Mesh front, Slope with Twin lids	340	2020	1430	1510	970	1700
FLM45BEL	4.5m <sup>3</sup> Frontlift bin, Mesh front, Box with Easylid	475	2020	1800	1880	1470	1750
FLM45BTL	4.5m <sup>3</sup> Frontlift bin, Mesh front, Box with Twin lids	430	2020	1800	1880	1470	1590
FLM45SEL	4.5m <sup>3</sup> Frontlift bin, Mesh front, Slope with Easylid	475	2020	1800	1910	1270	1900
FLM45STL	4.5m <sup>3</sup> Frontlift bin, Mesh front, Slope with Easylid	430	2020	1800	1910	1270	1780
FLM45REL	4.5m <sup>3</sup> Frontlift bin, Mesh front, Rubber Slot with Easylid	445	2020	1800	1660	1500	2150
FLM45RTL	4.5m <sup>3</sup> Frontlift bin, Mesh front, Rubber Slot with Twin lids	400	2020	1800	1510	1500	1980
FLM60REL	6.0m <sup>3</sup> Frontlift bin, Mesh front, Rubber Slot with Easylid	525	2020	1800	1870	1500	2150
FLM60RTL	6.0m <sup>3</sup> Frontlift bin, Mesh front, Rubber Slot with Twin lids	480	2020	1800	1870	1500	1980

Please note that dimensions are nominal and some variation may occur.

# TWIN LIDS FOR FRONTLIFT BINS

Easyquip Twin lids for Frontlift bins are a strong and versatile design that can be fitted to new bins or purchased separately as replacement parts. These lids are designed with two hinge tube holes and three lid stay holes so they can be fitted to almost any Frontlift bin as replacement for other lid designs.

Moulded from High quality LLDPE with unique stiffening ribs to reinforce the lid prop and hinge area, these lids are designed to be a much more durable and long lasting lid. Tests have proven them to be significantly stronger than other twin lid options currently available.

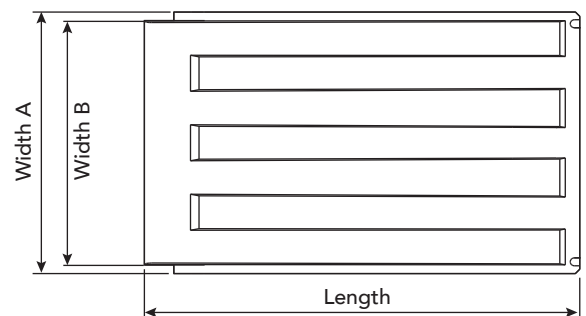
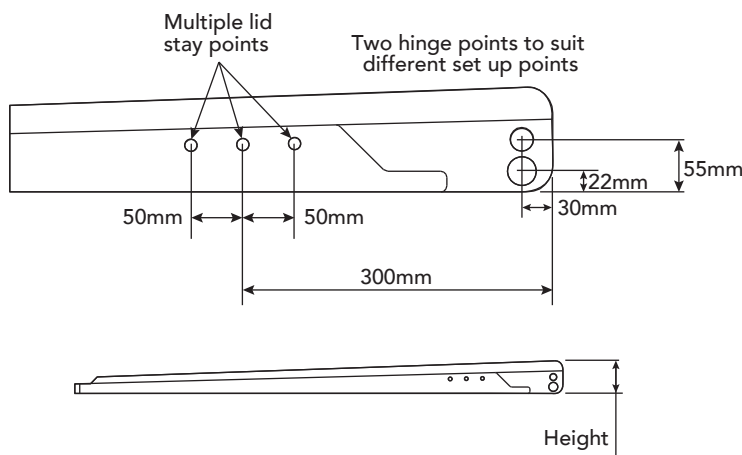

Item Code	Description	Length (mm)	Width A (mm)	Width B (mm)	Height (mm)	Weight (kg)
TL15	Twin lid for 1.5m <sup>3</sup> Frontlift bin	1050	915	855	120	8
TL30	Twin lid for 3.0 - 6m <sup>3</sup> Frontlift bin	1510	915	855	120	12.5

Please note that these dimensions are nominal, some variation may occur.

## STANDARD COLOURS



# PROP-A-LID FOR FRONTLIFT BINS

As a premium safety product, the Prop-A-Lid is a 3.0m-6.0m single-piece, spring assisted lid including a centrally mounted ratchet style lid-stay mechanism, operated via handles at each side. Proven benefits of a single-piece lid are retained by its design - including reduced rainwater and vermin ingress. These benefits, along with the unique internally mounted lid stay, results in a market-leading, safe, durable and easy-to-use lid system for frontlift bins.



## FEATURES

- Reduced maintenance & disposal costs.
- Reduced OH&S risks.
- Reduced vermin entry.

## SPECIFICATIONS

- Lid - rotationally moulded LLDPE plastic.
- Ratchet style lid stay, centrally mounted with springs - zinc plated.
- Handle bar with handle ends - galvanised steel.
- Hinges - laser cut steel.

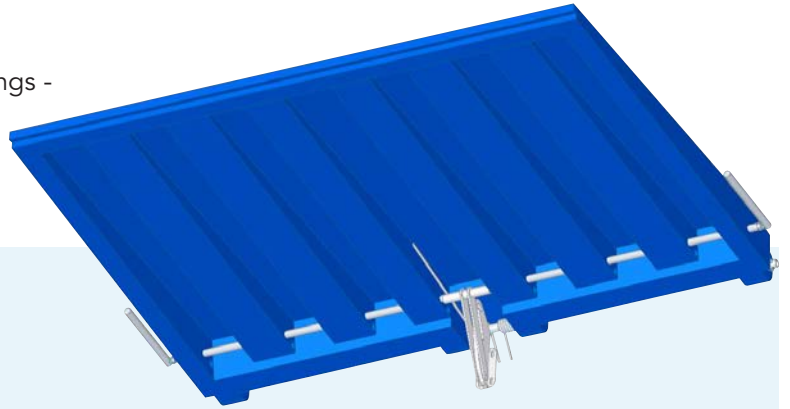

## OPTIONS

- Complete kits to fit to existing bins.
- Can be fitted during manufacture.
- Custom colour matching (min qty's apply).

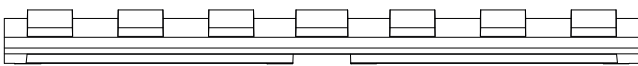

PLP30

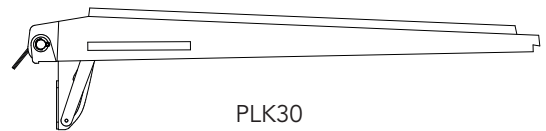
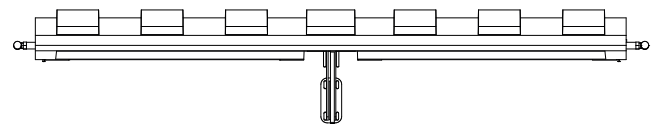

PLK30

Item Code	Description	Lift Weight (kg)	Overall Length (mm)	Overall Width (mm)	Opening Depth (mm)	Overall Height (mm)	Weight (kg)
PLP30	Prop-A-Lid Plastic 3.0m - 6.0m	-	1500	1880	1480	160	26
PLK30	Prop-A-Lid Kit 3.0m - 6.0m	5	1500	1880	1480	160	32

Please note that these dimensions are nominal and some variation may occur.

## STANDARD COLOURS





# EASYLID FOR FRONTLIFT BINS

Nearly 20 years ago we realized that waste companies throughout Australia were spending excessive amounts of money replacing broken plastic lids, paying higher tip fees due to rainwater in the waste, repairing prematurely rusted out bins. Most importantly, users were being exposed daily to significant OH&S risks.

Easyquip developed the Easylid, the only single piece, counter-weighted plastic lid for frontlift bins as the solution to reduce maintenance, tipping costs and address the OH&S risks.

## FEATURES

- Reduced maintenance & disposal costs.
- Extended bin life.
- Reduced OH&S risks.
- Reduced odour.
- Reduced vermin entry.

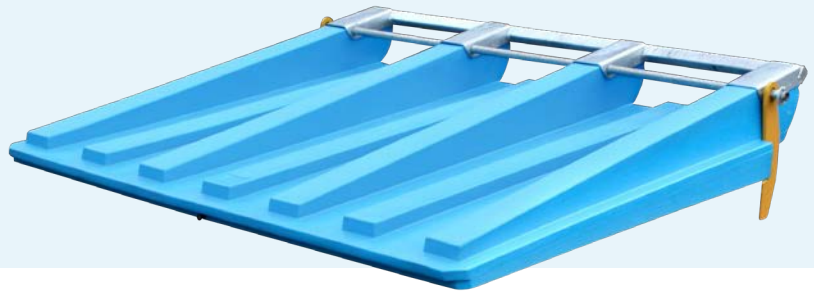

## SPECIFICATIONS

- Lid – Rotationally moulded LLDPE plastic.
- Counterweight – Galvanized steel.
- Hinge tube – Galvanized Steel.
- Hinges – Laser cut steel.
- M10 Brass insert for lock chains.



## OPTIONS

- Complete kits to fit to existing bins.
- Can be fitted to bins during manufacture.
- Custom colour matching (minimum quantities apply).

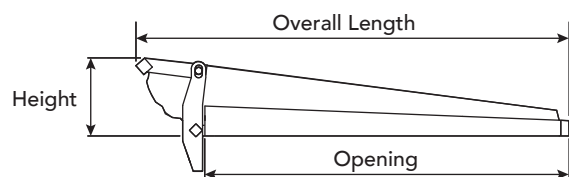
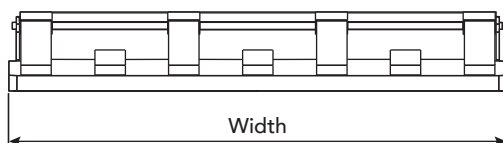

Item Code	Description	Lift Weight (kg)	Overall Length (mm)	Overall Width (mm)	Opening Depth (mm)	Overall Height (mm)	Weight (kg)
ELP15	1.5m <sup>3</sup> Easylid Frontlift bin lid (plastic part only)	N/A	110	1880	870	210	16
ELK15	1.5m <sup>3</sup> Easylid Frontlift bin lid (Full kit including hinges)	3	1120	1880	870	220	45
ELP30	3.0m <sup>3</sup> Easylid Frontlift bin lid (plastic part only)	N/A	1630	1880	1350	280	26
ELK30	3.0m <sup>3</sup> Easylid Frontlift bin lid (Full kit including hinges)	5	1650	1880	1350	290	70

Please note that these dimensions are nominal and some variation may occur.

## STANDARD COLOURS



# LOADING DOCK FRONTLIFT BIN

Easyquip side hinged lids are manufactured to suit 3.0m<sup>3</sup> & 4.5m<sup>3</sup> frontlift bins, with a design developed to reduce OH&S risks and bin emptying presentation time.



## FEATURES

- No requirement for the bin to be turned around during presentation time.
- Eliminates the need to reach over bin to open or close the lid.
- One handed opening and closing operation.
- No lid stay injuries.
- Wide opening for top loading.

## SPECIFICATIONS

- Lid – Rotationally moulded LLDPE plastic.
- Counterweights – Galvanised steel.
- Hinge tubes – Galvanised steel.
- Hinges – Laser cut steel.



## OPTIONS

- Kits available to suit 3.0m<sup>3</sup> & 4.5m<sup>3</sup> frontlift bins.
- Can be fitted to bins during manufacture.
- Complete kits to fit existing bins.

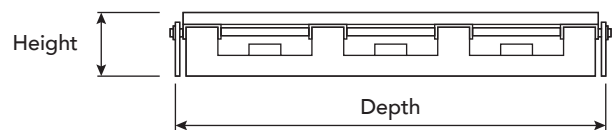
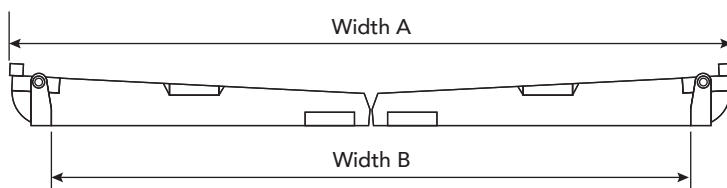

Item Code	Description	Lift Weight (kg)	Width A (mm)	Width B (mm)	Overall Depth (mm)	Overall Height (mm)
ELK2SH	Side Hinged Easylid Kit complete top assembly to suit 3.0m <sup>3</sup> & 4.5m <sup>3</sup>	6	2060	1840	1530	190
ELP2SH	Side Hinged lid plastic part only (require 2 per bin)	N/A	1000	1000	1490	125

Please note that these dimensions are nominal and some variation may occur.

## STANDARD COLOURS



# HOOKLIFT BINS

Easyquip Hooklift bins are a strong and durable design suited to all waste types including scrap metal and demolition work.

Rated to a SWL of 12 tonne, the 5mm walls and heavy RHS sections of this design offer greater resistance to damage while the smooth side profile gives a clean attractive appearance and signage can be easily fitted.

Custom built to your specific requirements and design upon request.

## FEATURES

- Engineer approved 12 tonne SWL.
- Strong and durable design.
- Consistent quality.

## SPECIFICATIONS

- SWL 12 Tonne.
- 5mm Mild Steel Bin Body.
- 100x100x5 Wall RHS.
- Main rails 230 PFC channel with 5mm reinforcing gussets.
- 50mm Diameter High Carbon steel lift pin.
- Floor cross members 50x50x4 RHS.
- Front Beam and A frame 230 PFC.
- Ratchet operated over-centre door lock.
- Greaseable Hinges.
- Greaseable 150mm rear rollers.
- Door safety chain fitted with Latching Hook.
- Primed and painted in Industrial Enamel to colour of choice.



## OPTIONS

- 2 Pak paint.
- Lid and Tarps.
- Door seal.
- Ladders.
- Hook-Dino combination.
- De-watering floor.
- Galvanizing (available up to 15m3).
- Craneable bins.
- Internal divider doors.
- QT450 Floor and Walls (Hardox or similar).
- Custom designs.
- Non-standard sizes.



# HOOKLIFT BINS

Continued

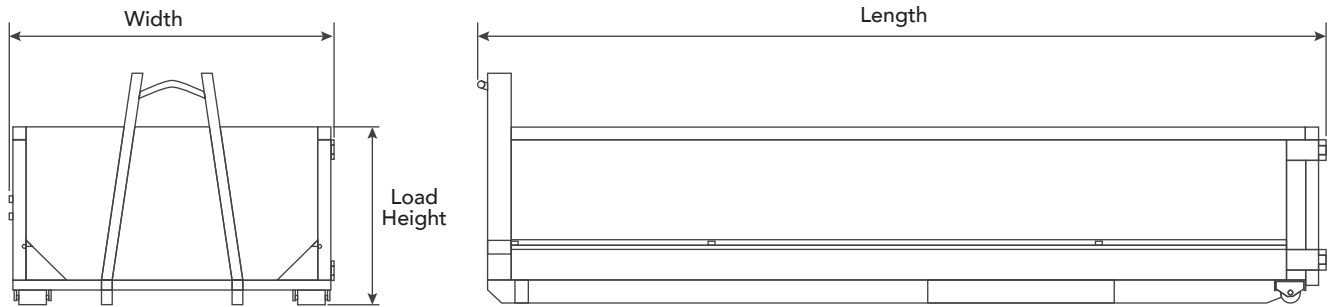

Item Code	Description	Overall Length (mm)	Overall Width (mm)	Load Height (mm)
HL401606	6m <sup>3</sup> Hooklift bin, 4m long x 1.4m wide Internal	4425	1700	1375
HL482006	6m <sup>3</sup> Hooklift bin, 4.88m long x 1.8m wide Internal	5300	2100	940
HL482008	8m <sup>3</sup> Hooklift bin, 4.88m long x 1.8m wide Internal	5300	2100	1160
HL482010	10m <sup>3</sup> Hooklift bin, 4.88m long x 1.8m wide Internal	5300	2100	1380
HL482012	12m <sup>3</sup> Hooklift bin, 4.88m long x 1.8m wide Internal	5300	2100	1600
HL482015	15m <sup>3</sup> Hooklift bin, 4.88m long x 1.8m wide Internal	5300	2100	1930
HL482406	6m <sup>3</sup> Hooklift bin, 4.88m long x 2.2m wide Internal	5300	2500	850
HL482408	8m <sup>3</sup> Hooklift bin, 4.88m long x 2.2m wide Internal	5300	2500	1000
HL482410	10m <sup>3</sup> Hooklift bin, 4.88m long x 2.2m wide Internal	5300	2500	1180
HL482412	12m <sup>3</sup> Hooklift bin, 4.88m long x 2.2m wide Internal	5300	2500	1370
HL482415	15m <sup>3</sup> Hooklift bin, 4.88m long x 2.2m wide Internal	5300	2500	1650
HL602406	6m <sup>3</sup> Hooklift bin, 6.0m long x 2.2m wide Internal	6400	2500	700
HL602408	8m <sup>3</sup> Hooklift bin, 6.0m x 2.2m wide Internal	6400	2500	850
HL602410	10m <sup>3</sup> Hooklift bin, 6.0m x 2.2m wide Internal	6400	2500	1000
HL602412	12m <sup>3</sup> Hooklift bin, 6.0m x 2.2m wide Internal	6400	2500	1150
HL602415	15m <sup>3</sup> Hooklift bin, 6.0m x 2.2m wide Internal	6400	2500	1400
HL602418	18m <sup>3</sup> Hooklift bin, 6.0m x 2.2m wide Internal	6400	2500	1600
HL602420	20m <sup>3</sup> Hooklift bin, 6.0m x 2.2m wide Internal	6400	2500	1800
HL602423	23m <sup>3</sup> Hooklift bin, 6.0m x 2.2m wide Internal	6400	2500	2000
HL602425	25m <sup>3</sup> Hooklift bin, 6.0m x 2.2m wide Internal	6400	2500	2150
HL602431-2C	31m <sup>3</sup> Hooklift bin, 6.0m x 2.2m wide Internal	6400	2500	2600
HL652435-2C	35m <sup>3</sup> Hooklift bin, 6.5m x 2.2m wide Internal	6900	2500	2700
HL702440-2C	40m <sup>3</sup> Hooklift bin, 7.0m x 2.2m wide Internal	7400	2500	2850

Please note that these dimensions are nominal and some variation may occur.

# CRANE CERTIFIED HOOKLIFT BINS

Easyquip Crane Rated Hooklift bins are a strong and durable design fitted with 4 lifting points and suited to all waste types including scrap metal and demolition work.

Engineered and Certified to Australian Standard AS4991-2004 lifting gear and rated to a WLL of 10 tonne, the 5mm floor and walls with the heavy RHS sections of this design offer greater resistance to damage while the smooth side profile gives a clean attractive appearance with a large flat area for signage.

## FEATURES

- Complies with AS4991-2005 Lifting Gear standard.
- 10 Tonne Crane lift WLL.
- NDT Test certificates supplied.

## SPECIFICATIONS

- 5mm Floor and Wall sheets.
- 150x100x6 Wall RHS.
- Main Rails 230 PFC Channel with 5mm Reinforcing gussets.
- 50mm Diameter, High Carbon steel lift pin.
- Floor crossmembers 50x50x3 RHS.
- Front Beam and A frame 230 PFC.
- Ratchet operated door lock.
- Greaseable hinges.
- Greaseable 150mm rear rollers.
- Door safety chain with latching hook.
- Primed and painted in Industrial Enamel to colour of choice.



## OPTIONS

- 2 Pak Paint.
- Lids and tarps.
- Door seals.
- Hardox floor and walls.



# CRANE CERTIFIED HOOKLIFT BINS

Continued

Item Code	Description	Overall Length (mm)	Overall Width (mm)	Load Height (mm)
HL401606C	6m <sup>3</sup> Crane Rated Hooklift bin, 4m long x 1.4m wide Internal	4425	1700	1375
HL482006C	6m <sup>3</sup> Crane Rated Hooklift bin, 4.88m long x 1.8m wide Internal	5300	2100	940
HL482008C	8m <sup>3</sup> Crane Rated Hooklift bin, 4.88m long x 1.8m wide Internal	5300	2100	1160
HL482010C	10m <sup>3</sup> Crane Rated Hooklift bin, 4.88m long x 1.8m wide Internal	5300	2100	1380
HL482012C	12m <sup>3</sup> Crane Rated Hooklift bin, 4.88m long x 1.8m wide Internal	5300	2100	1600
HL482015C	15m <sup>3</sup> Crane Rated Hooklift bin, 4.88m long x 1.8m wide Internal	5300	2100	1930
HL482406C	6m <sup>3</sup> Crane Rated Hooklift bin, 4.88m long x 2.2m wide Internal	5300	2500	850
HL482408C	8m <sup>3</sup> Crane Rated Hooklift bin, 4.88m long x 2.2m wide Internal	5300	2500	1000
HL482410C	10m <sup>3</sup> Crane Rated Hooklift bin, 4.88m long x 2.2m wide Internal	5300	2500	1180
HL482412C	12m <sup>3</sup> Crane Rated Hooklift bin, 4.88m long x 2.2m wide Internal	5300	2500	1370
HL482415C	15m <sup>3</sup> Crane Rated Hooklift bin, 4.88m long x 2.2m wide Internal	5300	2500	1650
HL602406C	6m <sup>3</sup> Crane Rated Hooklift bin, 6.0m long x 2.2m wide Internal	6400	2500	700
HL602408C	8m <sup>3</sup> Crane Rated Hooklift bin, 6.0m x 2.2m wide Internal	6400	2500	850
HL602410C	10m <sup>3</sup> Crane Rated Hooklift bin, 6.0m x 2.2m wide Internal	6400	2500	1000
HL602412C	12m <sup>3</sup> Crane Rated Hooklift bin, 6.0m x 2.2m wide Internal	6400	2500	1150
HL602415C	15m <sup>3</sup> Crane Rated Hooklift bin, 6.0m x 2.2m wide Internal	6400	2500	1400
HL602418C	18m <sup>3</sup> Crane Rated Hooklift bin, 6.0m x 2.2m wide Internal	6400	2500	1600
HL602420C	20m <sup>3</sup> Crane Rated Hooklift bin, 6.0m x 2.2m wide Internal	6400	2500	1800
HL602423C	23m <sup>3</sup> Crane Rated Hooklift bin, 6.0m x 2.2m wide Internal	6400	2500	2000

Please note that these dimensions are nominal and some variation may occur.

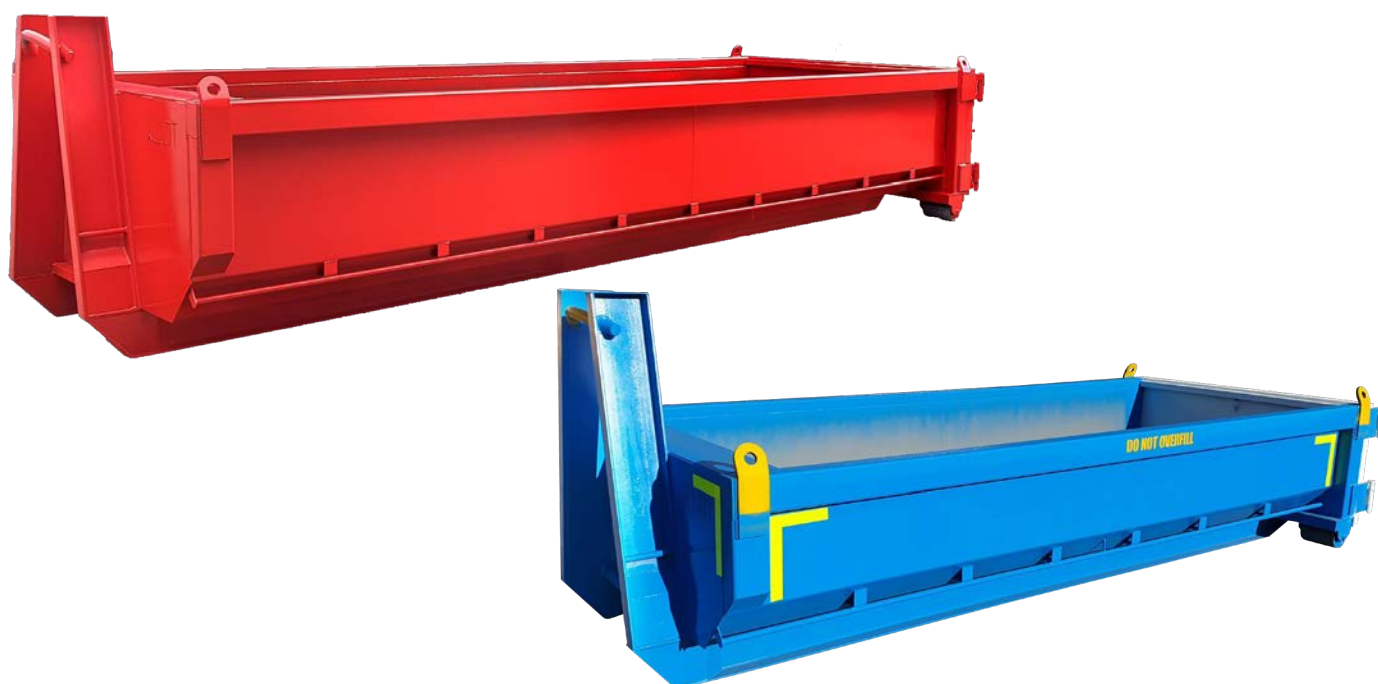

# HOOKLIFT SLUDGE BINS

The Easyquip sludge bin has been carefully designed to provide safe and secure transportation of semi-solid to liquid deposits from municipal, industrial and commercial plants. A forward mounted lock system is incorporated for easy use and allows the driver or operator to keep clear of any splash. To ensure we provide a functional and secure product, each bin is worked through a thorough waterproofing test before handover.

## FEATURES

- Safe & secure transportation of sludge.
- Strong and durable design.
- Forward mounted lock system to keep clear of splash.
- Customisable to suit loading requirements.
- Easy to operate.

## SPECIFICATIONS

- SWL 12 Tonne.
- Standard hooklift specs.
- Top hinged door.
- Door seals and locks.
- Hydraulic lid with seal and locks.

## OPTIONS

- Battery drill adaptor for hydraulic lid.
- Options for load hatches.
- Options for drainage valves.
- Upgraded paint spec.

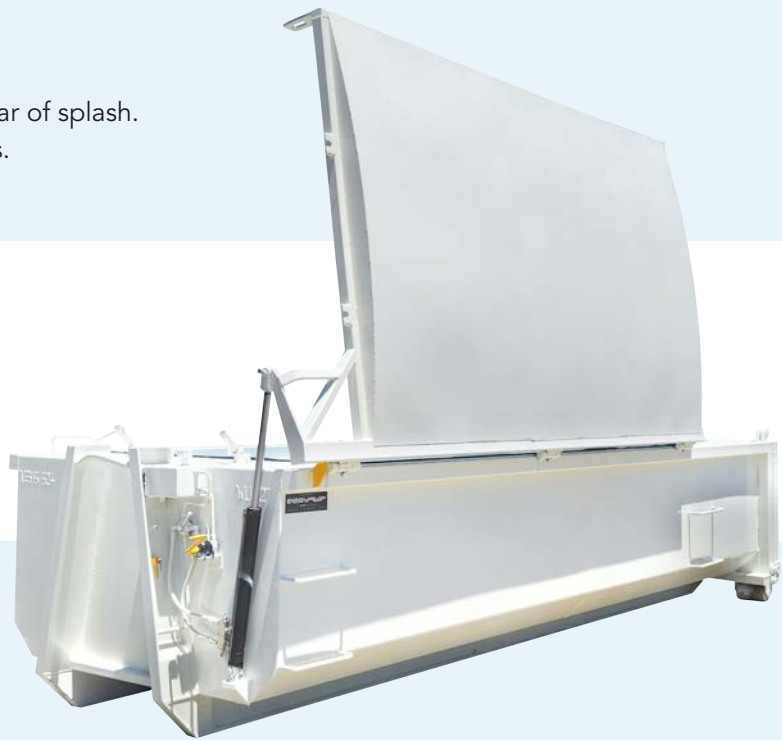

# HOOKLIFT MINI BINS

Easyquip's mini hooklift bins provide an affordable solution for waste collection and transportation within confined areas. Keeping strength and durability in mind, their smaller design is ideal for lower volume jobs and easily comply to weight restrictions. These bins can be custom-built to your specific requirements and design upon request.



## FEATURES

- Strong and durable design.
- Consistent quality.
- Compatible with small volumes and spaces.

## SPECIFICATIONS

- SWL 12 Tonne.
- 5mm Mild Steel Bin Body.
- 100x100x5 Wall RHS.
- Main rails 230 PFC channel with 5mm reinforcing gussets.
- 50mm Diameter High Carbon steel lift pin.
- Floor cross members 50x50x4 RHS.
- Front Beam and A frame 230 PFC.
- Ratchet operated over-centre door lock.
- Greaseable Hinges.
- Greaseable 150mm rear rollers.
- Door safety chain fitted with Latching Hook.
- Primed and painted in Industrial Enamel to colour of choice.

## OPTIONS

- 2 Pak paint.
- Lid and Tarps.
- Door seal.
- Ladders.
- Hook-Dino combination.
- De-watering floor.
- Galvanizing (available up to 15m3).
- Craneable bins.
- Internal divider doors.
- QT450 Floor and Walls (Hardox or similar).
- Custom designs.
- Non-standard sizes.



Item Code	Description	Overall Length (mm)	Overall Width (mm)	Load Height (mm)
HLM421706	6m <sup>3</sup> Mini Hooklift Bin, 4.2 long x 1.5m wide Internal	4460	1750	1140
HLM482006	6m <sup>3</sup> Mini Hooklift Bin, 4.8 long x 1.8m wide Internal	5060	2050	880
HLM482008	8m <sup>3</sup> Mini Hooklift Bin, 4.8 long x 1.8m wide Internal	5060	2050	1110
HLM482010	10m <sup>3</sup> Mini Hooklift Bin, 4.8 long x 1.8m wide Internal	5060	2050	1345

Please note that these dimensions are nominal and some variation may occur.



# HOOKLIFT TRAYS

Easyquip's Hooklift trays are a high quality, versatile product. The ability to use your Hooklift truck as a flat top tray increases the flexibility and can remove the requirement for additional assets.

## FEATURES

- Versatile.
- Customised to suit your needs.
- High quality.

## SPECIFICATIONS

- 3mm checker plate floor.
- A frame 200 PFC.
- Floor crossmembers 75x40.
- Greaseable 150mm rear rollers.
- 25mm diameter tie rails.
- Main rails 200 PFC channel with 5mm reinforcing gussets.
- Primed and painted in Industrial Enamel colour of choice.



## OPTIONS

- 5mm checker plate floor.
- 2 Pak paint.
- Binder Rails.
- Load Binders.
- Tray gates.
- Drop down sides.
- Loading ramps for the rear of tray.
- Custom designs.

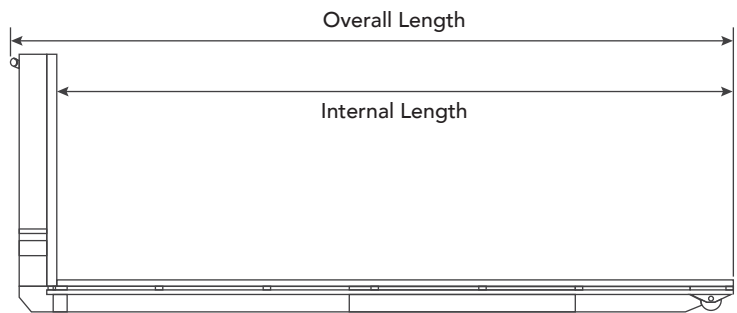
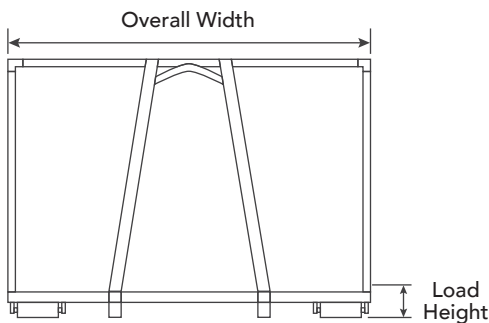

Item Code	Description	Floor Length (mm)	Overall Length (mm)	Overall Width (mm)	Load Height (mm)
HLT48	Hooklift tray, 4.8m Floor	4800	5100	2500	280
HLT60	Hooklift tray, 6.0m Floor	6000	6300	2500	280

Please note that these dimensions are nominal and some variation may occur.

# HOOKLIFT SKEL FRAMES

Hook lift Skel frames at Easyquip are designed and manufactured to efficiently mount and transport 20ft ISO shipping containers. These highly versatile frames can be an easy solution to businesses wanting to utilize containers, enabling transportation by hooklift truck.

## FEATURES

- Quality fabrication suited to 20ft ISO container.
- Versatile.

## SPECIFICATIONS

- 230 PFC A Frame with hook and stiffeners.
- 230 PFC Rear cross.
- 230PFC/180UB Main rails with stiffeners.
- SHS Mail rail diagonal braces.
- SHS Container support crossbeams.



## OPTIONS

- Gooseneck stop.
- Heavy duty greaseable rollers & brackets.
- Container twist locks.
- Galvanised finish.
- Customized designs.

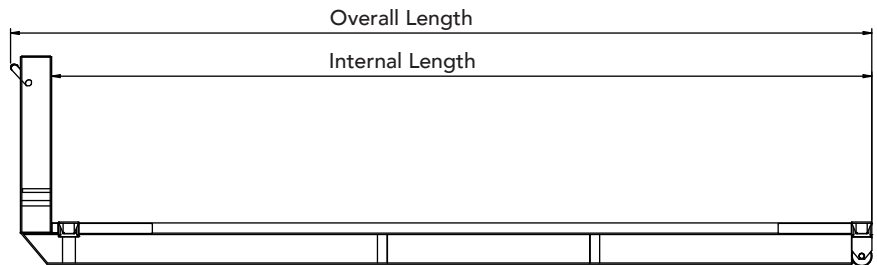
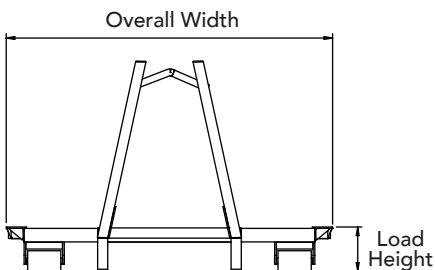
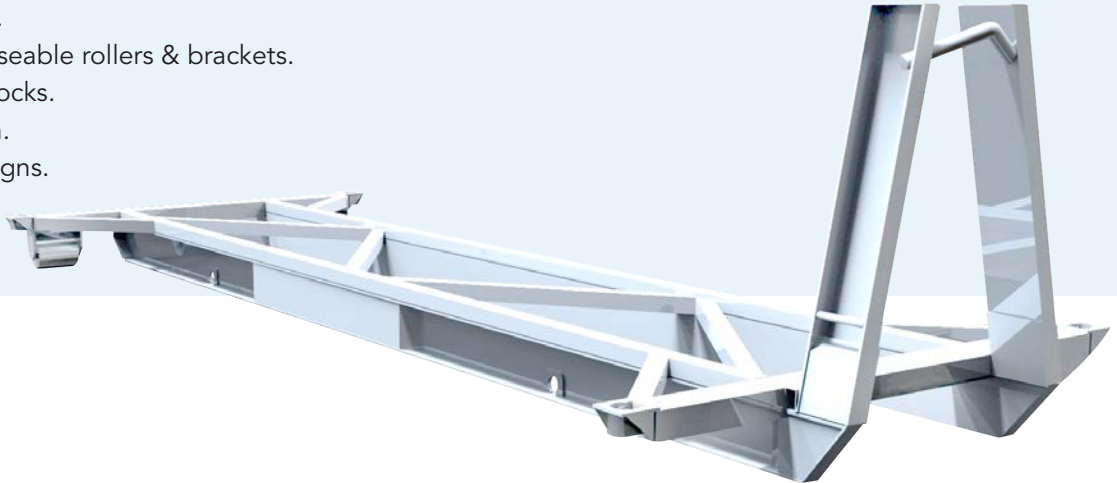

Item Code	Description	Internal/Floor Length (mm)	Overall Length (mm)	Overall Width (mm)	Load Height (mm)
HLSKEL	Hooklift Skel for 20ft Container	6053	6356	2409	327

Please note that these dimensions are nominal and some variation may occur.

# ROLLING LIDS FOR HOOKLIFT BINS

Easyquip 2 piece rolling metal lids are a strong and simple system to cover Hooklift bins. They can be padlocked to prevent un-authorised persons from accessing the bin. The lids are fitted to new bins during manufacture but can be retro-fitted to existing bins depending on their design and condition.

## FEATURES

- Removes OH&S risk.
- Easy to Operate.
- Minimal Maintenance.
- Durable.
- Lockable to prevent un-authorised access.



## SPECIFICATIONS

- RHS Frame.
- Solid metal sheeting.
- Nylon rollers.
- Primed and painted in Industrial Enamel.

## OPTIONS

- 2 Pak paint.
- Custom sizes.

Item Code	Description	Dimensions
HLLR	2 Piece rolling metal lid set for Hooklift bin	Suits bins from 4.5m to 7.0m long, dimensions vary to suit bin design

Please note that these dimensions are nominal and some variation may occur.

# HYDRAULIC LIDS FOR HOOKLIFT BINS

Easyquip has been supplying Hydraulic metal lids for over 10 years. This lid design is a highly durable design, is easy to operate and requires minimal maintenance. These lids can be made to suit new bins during the manufacturing process or retro-fitted to existing bins depending on bin condition and design.

## FEATURES

- Removes OH&S risk.
- Easy to Operate.
- Reduce litter.
- Minimal Maintenance.

## SPECIFICATIONS

- Curved RHS frame.
- Pilot check valves to prevent un-controlled descent.
- Corrugated sheeting.
- Single Hydraulic Cylinder.
- Manual or Electric pump to operate.



## OPTIONS

- Mesh Sheeting on lid.
- Solar power for electric pump.
- 240V power for electric pump.
- Battery drill adaptor manual pump.

### WATCH THE VIDEO

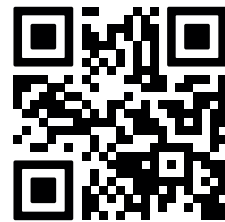

Item Code	Description	Dimensions
HLLMH	Metal lid for Hooklift bin opened with manual hydraulic pump	Suits bins from 4.5m to 7.0m long, dimensions vary to suit bin design
HLLRH	Metal lid for Hooklift bin opened with 3 phase electric hydraulic pump	Suits bins from 4.5m to 7.0m long, dimensions vary to suit bin design
HLLRTH	Metal lid for Hooklift bin opened with external hydraulic power pack	Suits bins from 4.5m to 7.0m long, dimensions vary to suit bin design
HLLSOLAR	Metal lid for Hooklift bin opened with solar power	Suits bins from 4.5m to 7.0m long, dimensions vary to suit bin design

Please note that these dimensions are nominal and some variation may occur.

# TARPS FOR HOOKLIFT BINS

Easyquip tarp systems to suit hooklift bins allow you to secure the contents of the bin preventing litter, rain water entry and other issues without the need for drivers to climb on the bin to tarp the load.



## FEATURES

- Removes OH&S risk.
- Easy to operate.
- Saves time.
- Prevent rain water entering bin.

## SPECIFICATIONS

- Grain Spec PVC Tarp.
- Metal Hoops.

Item Code	Description	Dimensions
HLTSTS	Side-to-side Rolling PVC tarp fitted to Hooklift bin	Suits bins from 4.5m to 7.0m long, dimensions vary to suit bin design
HLFTB	Wind Out PVC tarp fitted to Hooklift bin	Suits bins from 4.5m to 7.0m long, dimensions vary to suit bin design

Please note that these dimensions are nominal and some variation may occur.

# PLASTIC LIDS FOR HOOKLIFT BINS

Easyquip can supply hooklift bins fitted with a solid roof and Easylid counterbalanced lids. This lid system is ideal for un-manned transfer stations and other sites where the bins are being hand-loaded and rubbish content requires a secure cover.

## FEATURES

- Removes OH&S risk.
- Easy to Operate.
- Durable.
- Lockable.
- Prevents rain-water entering bin.

## SPECIFICATIONS

- RHS Frame.
- 3mm Steel sheeting.
- Easylid counterbalanced lids.
- Primed and painted in Industrial Enamel.



Item Code	Description	Dimensions
HLLEL	Solid Roof for Hooklift bin with Easylid counterbalanced lids.	Suits bins from 4.5m to 7.0m long, dimensions vary to suit bin design

Please note that these dimensions are nominal and some variation may occur.

# LOAD SPREADING AUGER FOR HOOKLIFT BIN

Easyquip's load spreading auger can be incorporated within any hooklift bin with a solid or hydraulic lid. Purposed for the processing of commercial and industrial general waste, and recyclable waste, the auger flights will direct waste away from the loading point to each end of the bin. While in operation, the system is kept fully enclosed with an externally mounted control box. To make it as safe as possible, the system also features additional safety measures including a safety interlock system and emergency stop point, without restricting its ease-of-use.

## FEATURES

- Reduced frequency of bin emptying.
- Safety measures including interlock system and emergency stop button.

## SPECIFICATIONS

- Auger set up incl. structural support materials.
- Internally mounted electric motor and gearing.
- UC-210 bearing and FL-210 housing
- 32A 3 phase electrical inlet.
- Externally mounted electrical control box with emergency stop.



## OPTIONS

- Fully customisable (including auger configurations and lid or bin mounted design).



# FORKLIFT BIN

Easyquips new heavy duty forklift bins are made suitable for the storage and transportation of scrap metal and other bulk materials. With internal fork pockets and a stable stacking set-up, these bins have been designed along-side their own custom lids, which are able to remain fitted within a stack.



## FEATURES

- Strong, durable design.
- Full length internal fork pockets.
- Stackable.
- Easily transportable.

## SPECIFICATIONS

- 3mm body sheets.
- 3x50x50 SHS top wall reinforcing.
- Stacking plates and stacking pins.
- 5mm internal fork pockets with bash plates.
- Primed and painted in equipment enamel.



## OPTIONS

- Drainage Socket and plug.
- Drain Holes in floor.
- Sealed floor for regulated waste.
- Hot dip galvanised finish.
- 2 Pak paint.
- Specifically designed plastic lids to fit within stack (2per bin).

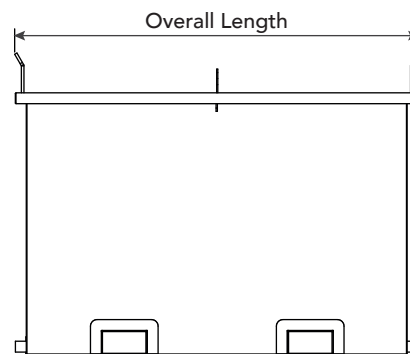
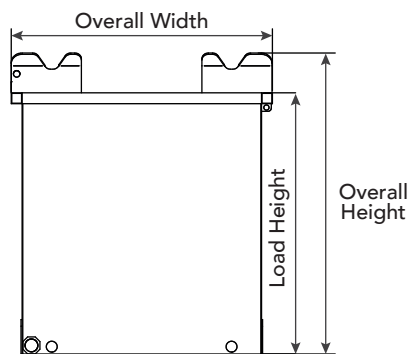

Item Code	Description	Capacity (m <sup>3</sup> )	Width (mm)	Depth (mm)	Load Height (mm)	Fork Spacing (mm)
FB444	Forklift Bin 1200 x 1200 x 1300 (4x4x4)	1.8	1200	1200	1300	1060
FB644	Forklift Bin 1840 x 1200 x 1300 (6x4x4)	2.2	1800	1200	1300	1060
FB844	Forklift Bin 2440 x 1200 x 1300 (8x4x4)	3	2400	1200	1300	1060

Please note that these dimensions are nominal and some variation may occur.



# SCRAP BIN

The Easyquip scrap bin is a 2T crane rated, heavy duty design suitable for the storage and transport of scrap metal and other bulk materials. All bins are fitted with lifting lugs and fork pockets.

## FEATURES

- 2T crane rated bin certification.

## SPECIFICATIONS

- 250grade 3mm wall sheets.
- 250grade 5mm floor sheet with drain holes.
- 8mm angled crane lift lugs.
- 75x50x4 RHS top support frame
- 5mm profile cut fork pockets.
- 5x50x50 angle fork pocket reinforcements.
- Primed and painted in industrial enamel of your choice.



## OPTIONS

- Upgrade to paint spec.
- Hot dip galvanised finish.
- Sealed floor.

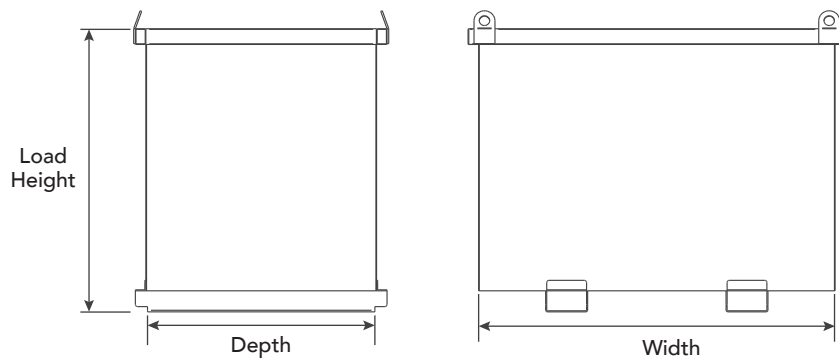

Item Code	Description	Capacity (m <sup>3</sup> )	Width (mm)	Depth (mm)	Load Height (mm)	Fork Spacing (mm)
SB444	Scrap bin 1200x1200x1300 (4x4x4)	1.63	1200	1200	1300	1060
SB644	Scrap bin 1800x1200x1300 (6x4x4)	2.3	1800	1200	1300	1060
SB844	Scrap bin 2400x1200x1300 (8x4x4)	3.1	2400	1200	1300	1060

Please note that these dimensions are nominal and some variation may occur.

# ROLL OVER TIPPLER BINS

Roll over Forklift Tippler Bins provide an efficient solution in many materials handling areas. With a smooth, balanced roll over tipping action they can be easily operated from the driver's seat of the forklift. These bins are available from standard with a "Push Button" release mechanism. They can also be optioned with a release lever.

## FEATURES

- Smooth, balanced tipping action.
- Operator can remain on Forklift.
- 1000kg SWL.

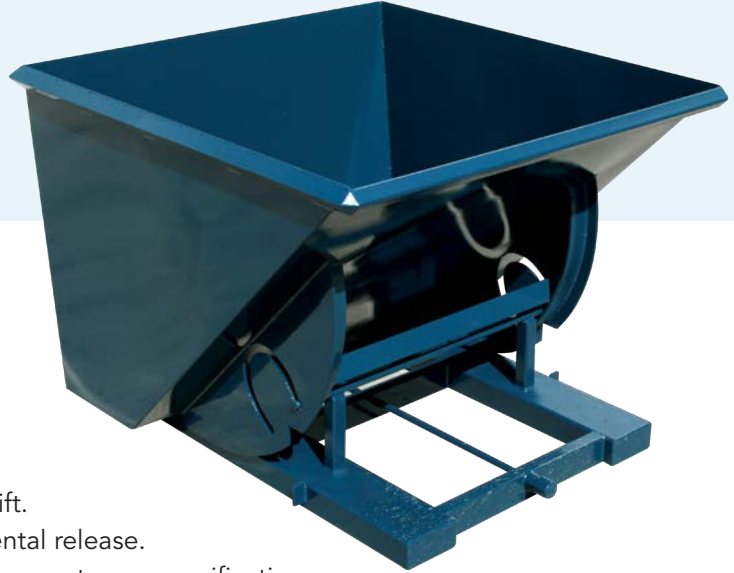

## SPECIFICATIONS

- Forklift Tine Pockets 100x200x4 RHS.
- Bin Body 3mm Steel.
- Reinforcing 50x50x5 Angle and 50x50x4 RHS.
- Rolling Plates 10mm GR250 Steel.
- Rolling surface 75x10 Flat Bar.
- Fitted with Retainer chain to secure bin to forklift.
- Fitted with safety chain to guard against accidental release.
- Primed and painted in Industrial Enamel or as per customer specifications.

## OPTIONS

- Lever release.
- Castors.
- 2 Pak paint.

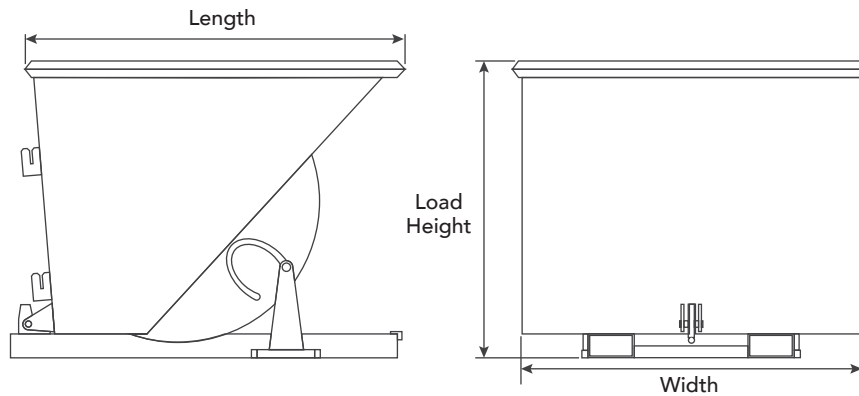

Item Code	Description	Length (mm)	Width (mm)	Load Height (mm)	Fork Spacing (mm)
TBRO10	1.0m <sup>3</sup> Roll Over tippler bin	1450	1310	1050	1060
TBRO10C	1.0m <sup>3</sup> Roll Over tippler bin with Crane lift certification	1450	1310	1050	1060
TBRO15	1.5m <sup>3</sup> Roll Over tippler bin	1670	1500	1200	1100
TBRO15C	1.5m <sup>3</sup> Roll Over tippler bin with Crane lift certification	1670	1500	1200	1100]
TBRO20	2.0m <sup>3</sup> Roll Over tippler bin	1670	1900	1200	1100
TBRO25	2.5m <sup>3</sup> Roll Over tippler bin	2040	1600	1460	1100
TBRO30	3.0m <sup>3</sup> Roll Over tippler bin	2040	1900	1460	1100

Please note that these dimensions are nominal and some variation may occur.

# DRAW BACK TIPPLER BINS

Draw Back Forklift Tippler Bins provide an efficient solution in the materials handling areas. With correct forklift operation these bins are a safe and easy way to transport waste and release it into a larger container or onto the ground.



## FEATURES

- Basic sturdy design.
- Operator can remain on Forklift.
- 1000kg SWL.
- Customised to suit your requirement.

## SPECIFICATIONS

- Forklift Tine Pockets 200x100x4 RHS'
- Bin Body 3mm Mild Steel.
- Reinforcing 50x50x5 Angle and 100x50x3 RHS.
- Fitted with Retainer chain to secure bin to forklift.
- Fitted with safety chain to guard against accidental release.
- Primed and painted in Industrial Enamel or as per customer specification.

## OPTIONS

- Custom Sizing.
- Lever Release.
- Lids.
- Heavy Duty Castors.
- 2 Pak Paint.
- Hot Dip Galvanised.
- Crane lift certification.

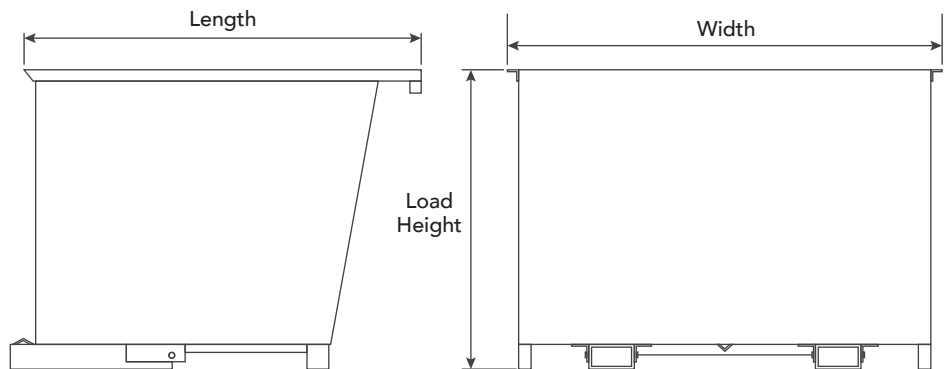

Item Code	Description	Length (mm)	Width (mm)	Load Height (mm)	Fork Spacing (mm)
TBDB05	0.5m <sup>3</sup> Draw Back tippler bin	1670	1000	1200	700
TBDB05C	0.5m <sup>3</sup> Draw Back tippler bin with Crane certification	1670	1000	1200	700
TBDB10	1.0m <sup>3</sup> Draw Back tippler bin	1670	1000	1200	700
TBDB10C	1.0m <sup>3</sup> Draw Back tippler bin with Crane certification	1670	1000	1200	700
TBDB15	1.5m <sup>3</sup> Draw Back tippler bin	1670	1500	1200	1100
TBDB15C	1.5m <sup>3</sup> Draw Back tippler bin with Crane certification	1670	1500	1200	1100
TBDB20	2.0m <sup>3</sup> Draw Back tippler bin	1670	1900	1200	1100
TBDB20C	2.0m <sup>3</sup> Draw Back tippler bin with Crane certification	2040	1600	1460	1100
TBDB25	2.5m <sup>3</sup> Draw Back tippler bin	2040	1900	1460	1100
TBDB25C	2.5m <sup>3</sup> Draw Back tippler bin with Crane certification	2040	1600	1460	1100
TBDB30	3.0m <sup>3</sup> Draw Back tippler bin	2040	1900	1460	1100
TBDB30C	3.0m <sup>3</sup> Draw Back tippler bin with Crane certification	2040	1600	1460	1100

Please note that these dimensions are nominal and some variation may occur.

# TRANSPORTABLE BLADE COMPACTORS

Transportable Blade Compactors consist of a Compaction Unit that uses Hydraulic force to drive a blade to compact waste material into a Receiver Bin. The compaction unit and the bin are joined together in one integrated unit which is taken away for emptying. Hooklift trucks are the most common transport system but they can also be built to suit Dino trucks and Marell Skip trucks.

Transportable Blade Compactors are used to prevent material spillage when the bin is emptied, they are also used for sites that do not require a large Stationary Compactor or for short term applications such as events. Transportable Blade compactors are not ideal for wet or putrescible waste as the material can get trapped behind the blade, causing leakage and other issues.

With cross cylinder design, PLC controls, a range of standard loading hoppers to suit most applications and the ability to provide custom solutions to fit your specific needs, Easyquip Transportable compactors are another solution to your waste problem.

## FEATURES

- Compact design with large filling opening.
- Sealed access doors for servicing.
- Cut transport costs by compacting waste.
- Reduced congestion and environmental impact.



## SPECIFICATIONS

- Container 75% and 100% full light.
- All functions controlled by PLC.
- 2 Pak Poly-Urethane Paint.
- Designed in accordance with Australian Standards.

## OPTIONS

- Standard and custom loading hoppers.
- Bin tipping mechanisms.
- Fill level and other notifications via SMS technology.

# STATIONARY TWIN AUGER COMPACTORS

Our stationary twin auger compactor is a heavy-duty version of our standard auger compactor, fitted with two augers to break down the waste material and force it into a receiver bin. As with all stationary compactors, the compaction unit remains in a fixed location while the receiver bin is disconnected and taken away for emptying.

With a much higher capacity and higher compaction ratios compared to single auger machines, our twin auger compactors are designed for sites that need to quickly deal with large volumes of waste material.

All Easyquip auger compactors are fitted with our patented auger drive system, with a sealed-for-life planetary gear box and direct drive to produce unmatched strength. This reduces the risk of breakdown and saves money on service requirements.

With a range of standard loading hoppers to suit many different applications and the ability to design and build custom solutions to fit your specific needs, Easyquip brings ideal solutions to your high-volume waste problem.

## FEATURES

- 2 X 11KW electric motor.
- 2 Pak Poly-Urethane Paint.
- Designed in accordance with Australian standards.

## SPECIFICATIONS

- Container 75% and 100% full light.
- All functions controlled by PLC.

## OPTIONS

- Standard and custom loading hoppers.
- Pre-shredder systems.
- Bin tipping mechanisms.



# TRANSPORTABLE AUGER COMPACTORS

Transportable Auger Compactors consist of a Compaction Unit using an auger to break down the waste material and force it into a Receiver Bin. The compaction unit and the bin are joined together in one integrated unit which is taken away for emptying. Hooklift trucks are the most common transport system but they can also be built to suit Dino trucks and Marell Skip trucks. They are ideal for wet or putrescible waste streams as they can be fully sealed to prevent leakage and spillage of the waste. Transportable Compactors are also used for short term applications such as events and other sites that may not require a fixed Stationary Compactor.

Easyquip Transportable Auger Compactors are fitted with our patented Auger drive system with a sealed for life gearbox and direct drive to provide un-matched strength, reduced risk of breakdown and to save money on servicing. With the ability to be optioned for both wet and dry waste, a range of standard loading hoppers to suit most applications and the ability to design and build custom solutions to fit your specific needs, Easyquip Transportable Auger compactors are the ideal solution to your high-volume waste problem.



## FEATURES

- Unmatched strength with unique Auger design.
- Reduced service cost with Sealed gearbox and direct drive.
- Fully Sealed to prevent leakage.
- Pre-Crushing action of the screw offers better compaction compared to blade compactors.
- Cut transport costs by compacting waste.
- Reduced congestion and environmental impact.

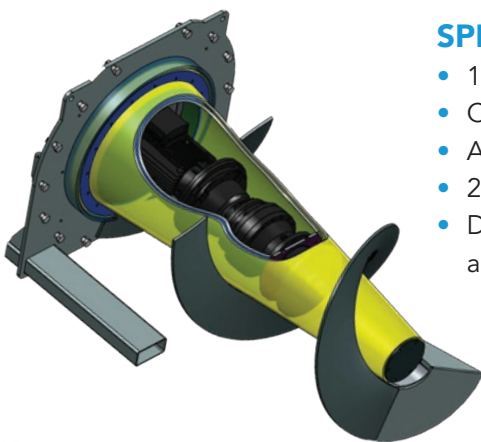

## SPECIFICATIONS

- 11KW Electric motor.
- Container 75% and 100% full light.
- All functions controlled by PLC.
- 2 Pak Poly-Urethane Paint.
- Designed in accordance with CE and Australian Standards.

## OPTIONAL EQUIPMENT

- Cardboard Feeder unit.
- Standard and custom loading hoppers.
- Bin tipping mechanisms.
- Fill level and other notifications via SMS technology.
- Door Seal.
- Liquid Drainage points.
- Double end pick up.

# STATIONARY BLADE COMPACTORS

Stationary Blade Compactors consist of a Compaction Unit that uses Hydraulic force to drive a blade to compact waste material into a Receiver Bin. The compaction unit remains in a fixed location but the Receiver Bin is disconnected from the Compaction Unit and taken away for emptying. Hooklift trucks are the most common transport system for the Receiver Bin but they can also be built to suit Dino trucks and Marell Skip trucks.

They are ideal for dry waste streams such as paper, cardboard, lightweight timber and plastics, Stationary Compactors can be optioned to suit General Waste but there will always be some material spilled on the ground when the Receiver Bin is taken away.

With cross cylinder design, PLC controls, a range of standard loading hoppers to suit most applications and the ability to provide custom solutions to fit your specific needs Easyquip Stationary Blade compactors offer another solution to your waste problem.

## FEATURES

- Compact design with large filling opening.
- Sealed access doors for servicing.
- Cut transport costs by compacting waste.
- Reduced congestion and environmental impact.

## SPECIFICATIONS

- Container 75% and 100% full light.
- All functions controlled by PLC.
- 2 Pak Poly-Urethane Paint.
- Designed in accordance with Australian Standards.

## OPTIONAL EQUIPMENT

- Standard and custom loading hoppers.
- Bin tipping mechanisms.
- Fill level and other notifications via SMS technology.



# STATIONARY AUGER COMPACTORS

Stationary Screw Compactors consist of a Compaction Unit that uses an auger to break down the waste material and force it into a Receiver Bin. The compaction unit remains in a fixed location but the Receiver Bin is disconnected from the Compaction Unit and taken away for emptying. Hooklift trucks are the most common transport system for the Receiver Bin but they can also be built to suit Dino trucks and Marell Skip trucks.

They are ideal for dry waste streams such as paper, cardboard, lightweight timber and some plastics, Stationary Compactors can be optioned to suit General Waste but this is usually avoided as there will always be some material spilled on the ground when the Receiver Bin is taken away.

Easyquip Stationary Screw Compactors are fitted with our patented Auger drive system with a sealed for life gearbox and direct drive to provide un-matched strength, reduced risk of breakdown and to save money on servicing. With a range of standard loading hoppers to suit most applications and the ability to design and build custom solutions to fit your specific needs, Easyquip Stationary Screw compactors are the ideal solution to your high-volume waste problem.



## FEATURES

- Unmatched strength with unique Auger design.
- Reduced service cost with Sealed gearbox and direct drive.
- Pre-Crushing action of the screw offers better compaction compared to blade compactors.
- Cut transport costs by compacting waste.
- Reduced congestion and environmental impact.

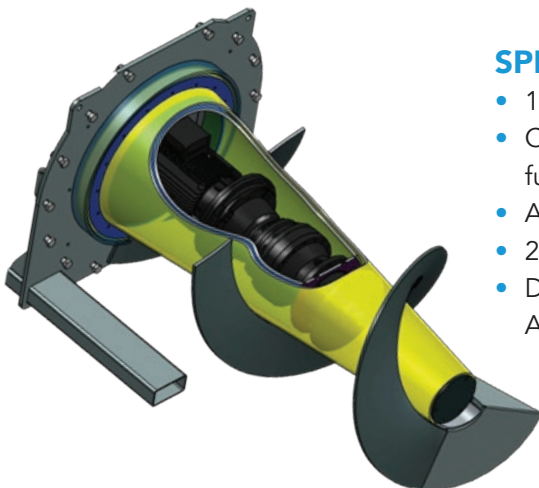

## SPECIFICATIONS

- 11KW Electric motor.
- Container 75% and 100% full light.
- All functions controlled by PLC.
- 2 Pak Poly-Urethane Paint.
- Designed in accordance with Australian Standards.

## OPTIONAL EQUIPMENT

- Cardboard Feeder unit.
- Standard and custom loading hoppers.
- Bin tipping mechanisms.
- Fill level and other notifications via SMS technology.
- Door Seal.



# COMPACTOR RECEIVER BINS

Easyquip can supply Compactor Receiver bins to suit any stationary compaction system. Our design features a smooth pressed side profile which offers strength, a clean attractive appearance and easy application of signage. As with all our products, Easyquip Compactor bins are finished to the highest standard.

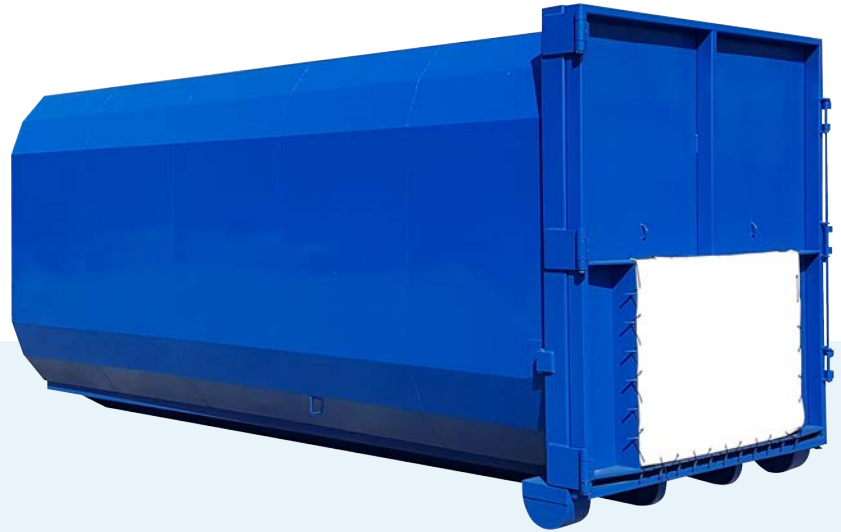

## FEATURES

- Smooth side profile for Signage.
- Low Tare weight.
- Consistent Quality.

## SPECIFICATIONS

- 5mm Mild Steel Floor.
- 3mm GR350 Mild Steel Side walls.
- 6mm Mild Steel Front wall.
- Main rails 200 PFC channel.
- Rear cross member 180 PFC.
- A frame 200 PFC.
- Ratchet operated over-center door lock.
- Greaseable Hinges.
- Greaseable 150mm rear rollers.
- Primed and painted in Industrial Enamel to colour of choice.
- Canvas compactor opening cover.

## OPTIONS

- 2 Pak paint.
- Steel compaction opening cover.
- Custom sizes.
- QT450 Floor and Walls (Hardox or similar).

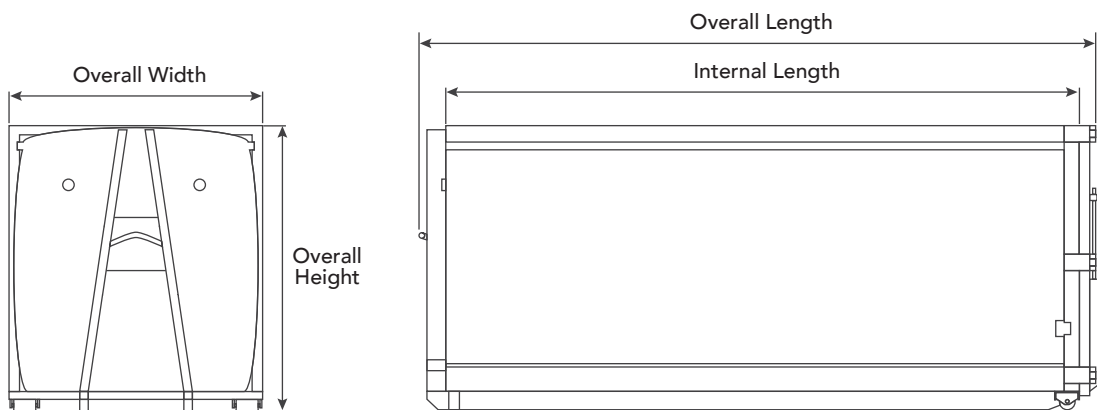

Item Code	Description	Capacity (m <sup>3</sup> )	Floor Length (mm)	Overall Length (mm)	Overall Width (mm)	Load Height (mm)
CRB30	Compactor Receiver Bin	30	6000	6500	2500	2700
CRB40	Compactor Receiver Bin	40	7000	7500	2500	2950

Please note that these dimensions are nominal and some variation may occur.







**easyquip**  
IT CAN BE DONE

**VICTORIA**

135 Firmins Lane  
Hazelwood North VIC 3840

**QUEENSLAND**

299 Stapylton Road  
Heathwood QLD 4110

 1300 797 543  
 [www.easyquip.com.au](http://www.easyquip.com.au)

---

While Easyquip has made all reasonable efforts to ensure that details given in this catalogue are accurate at the time of publication, full technical specifications are not included and Easyquip reserves the right to alter specifications, details and information from time to time without notice to customers. Since the use of this information and the conditions in which these products are used are beyond the control of Easyquip, a user must determine whether the products are suitable for the purpose for which they are to be used, and is responsible for the safe use of the products.